

NR	NUMER CZĘŚCI	OPIS	ILOŚĆ
1	cep s1	#10, główny	12
2	luk-bok s1	#10, V1	1
3	luk srodek	#10, standard	2
4	Lustroluk-bok		1
5	oslona	#4	1
6	wzm oslony	#4, skrajny	2
7	wzm oslony	#4, śodkowy	2
8	pret moc	fi 25	1
9	Lustropret moc		1
10	moc v2	fi 44,6x14	2
11	moc v1	fi25x36	2
12	pret dystansowy	fi 12	2
13	os	fi19	2
14	drut	fi 4 długi	61
15	kat bazujacy		3

OSKO-PLAST
 Stara Dąbia 9, 08-500 Ryki
www.osko-plast.pl

TYTUŁ:

NH CR 9090
 klepisko główne zbożowe

NR RYSUNKU

CR9090.KGZS1.001

Data:

2019-06

A4

SKALA:1:7

ARKUSZ 1 Z 2

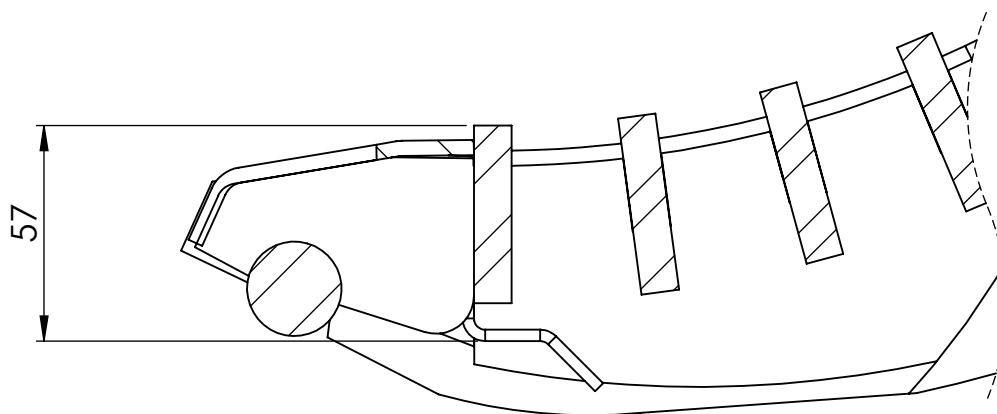
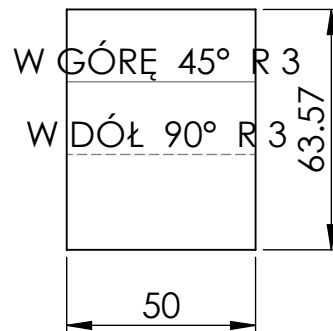
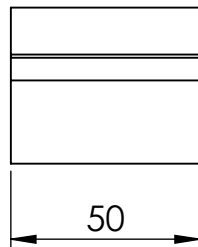
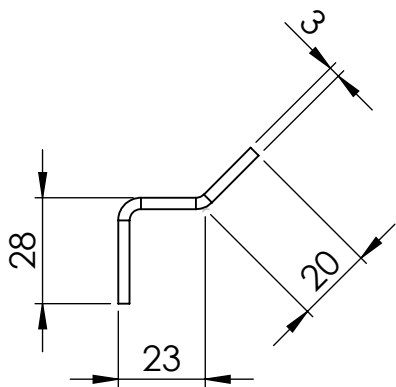

OSKO-PLAST
 Stara Dąbia 9, 08-500 Ryki
 www.osko-plast.pl

TYTUŁ:

NH CR 9090
 klepisko główne zbożowe

NR RYSUNKU

CR9090.KGZS1.002

Data:

2019-06

A4

SKALA: 1:2

ARKUSZ 2 Z 2